



QUICK SPECS

Weight	2,348 lbs
Horsepower	10.3 hp
Digging Depth	5'4"

Works effortlessly in virtually any narrow, tight, cramped space.

Our smallest excavator sets the standard for efficient work in confined spaces. A tenacious worker, the SV08 is unfazed by housing foundations, indoor renovation, pipe-laying, landscaping and other challenges in hard-to-reach places. Adjustable width tracks let you maneuver through gaps as narrow as 2ft - 3in, and a variable undercarriage lets you work safely on slopes or steps. Plus, the powerful, 10.3-hp, interim Tier 4 engine is environmentally friendly with clean exhaust and very low noise.

INNOVATIVE FEATURES



Adjustable Width Tracks To Squeeze Almost Anywhere

The track width of the SV08-1A narrows to 2ft-3in (680 mm) to fit through narrow passages, and expands to 2ft-9in (840 mm) for stability while working. In addition, the super compact body features an ultra-tight turning radius of 2ft-5in (725 mm), and keeps rear overhang to just 1in (305 mm).



Easy Accessibility For Routine Maintenance

The engine is conveniently located right under the operator's seat. Simply lift up and fold back the seat for quick, easy access to all major components. Routine maintenance is always a breeze.



Foldable ROPS

The durable, foldable ROPS system helps protect the operator from injury and folds down to allow passage through spaces as tight as a standard doorway.

SV08-1A

POWERFUL, EFFICIENT
10.3-HP INTERIM TIER 4
YANMAR DIESEL ENGINE

TWO-WAY CONTROL
PATTERN CHANGE

STANDARD AUXILIARY
HYDRAULICS W/
PROPORTIONAL
CONTROL STANDARD

VARIABLE
UNDERCARRIAGE
IMPROVES STABILITY

OPERATOR-FRIENDLY,
UNCOMPLICATED LEVER
CONTROLS

COMFORTABLE
OPERATOR SEAT

COVERED BOOM
CYLINDERS AND
HYDRAULIC HOSES

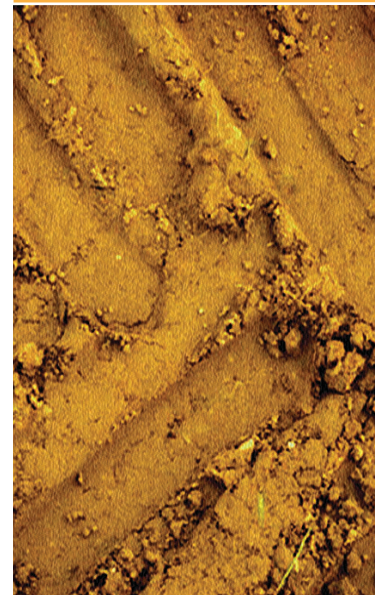

SV08-1A

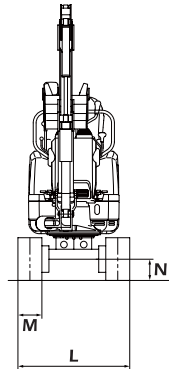
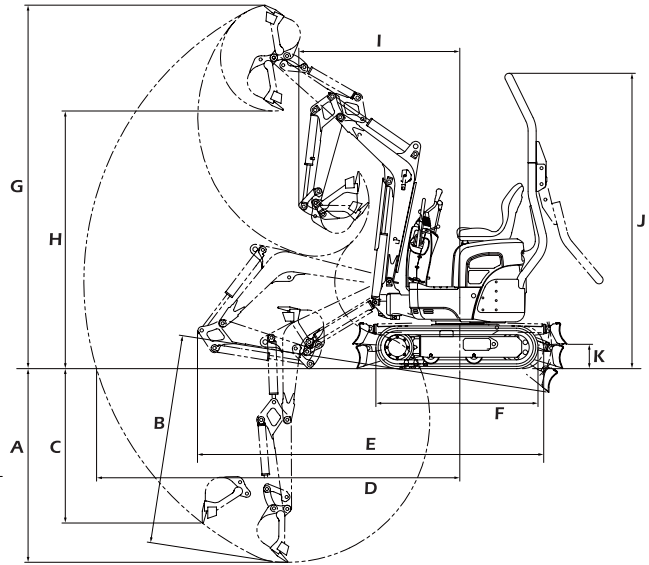
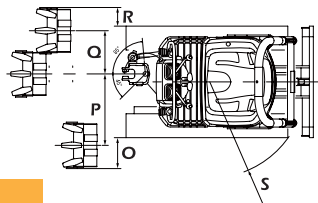

Dimensions - SV08-1A

A 4'7"-4'11" (1400-1500)	K 7'-11" (180-280)
B 5'-5'4" (1520-1620)	L 2'3"-2'9" (680-840)
C 3'10"-4'2" (1160-1260)	M 7" (180)
D 8'10"-8'11" (2700-2730)	N 5'-9" (130-230)
E 8'6" (2600)	O 9'-1" (230-310)
F 4' (1220)	P 1'9" (540)
G 9'-9'4" (2750-2850)	Q 1'1" (330)
H 6'5"-6'9" (1950-2050)	R 6'-9" (140-220)
I 3'10" (1180)	S 2'5" (725)
J 7'3"-7'7" (2200-2300)	

Specifications

Model		SV08-1A	
Operating Weight	Rubber track	lbs (kg)	2348 (1065)
Engine	Type	-	Water-cooled 2-cylinder diesel
	Model	-	YANMAR 2TE 67L-BV3
	Output	HP (kW)/rpm	10.3 (7.7) / 2400
Performance	Max Digging Force, Bucket / Arm	lbs (kN)	2360 (10.5) / 1390 (6.2)
	Traveling Speed	MPH (km / h)	1.2 (1.8)
	Swing Speed	RPM	8.4
	Boom Swing Angle, (L / R)	degrees	45°/90°
Ground Contact Pressure (Rubber Track)		PSI (kPa)	4.15 (28.4)
Hydraulic System	Pump Capacity	GPM (L / min)	2.59 (9.8) x 2
	Main Relief Set Pressure	PSI (MPa)	2625 (18.1) x 2
Blade Dimensions	Width x height	ft-in (mm)	2'3"7/2"9" x 7" (680/840 x 180)
Fuel tank capacity		Gals (L)	2.6(10)

Standard Equipment

- Blade
- Boom Swing Function
- Rubber Tracks
- Variable Undercarriage
- Auxiliary Valve and Piping (boom end)
- Double Acting PTO
- 2-way Control Pattern Change
- Cylinder Cover (boom, blade)
- Foldable ROPS
- Standard Seat
- Seat Belt
- Operation Manual

Please note that the standard equipment may vary from this list. Consult your Yanmar dealer for confirmation.

Hydraulic PTO

Model		SV08-1A	
Specification	Output	PSI (MPa)	GPM (L / min)
			2400RPM
Combined Flow, Double Actions		2625 (18.1)	5.2 (19.6)

Lifting Capacity

LIFT POINT HEIGHT h:in (mm)	r:REACH in (mm)											
	RATED LIFT CAPACITY OVER END BLADE DOWN lbs (kg)				RATED LIFT CAPACITY OVER END BLADE UP lbs (kg)				RATED LIFT CAPACITY OVER SIDE BLADE DOWN lbs (kg)			
	MAX	6'7" (2000)	4'11" (1500)	MIN	MAX	6'7" (2000)	4'11" (1500)	MIN	MAX	6'7" (2000)	4'11" (1500)	MIN
6'7" (2000)	*485(220)				419(190)				353(160)			
4'11" (1500)	*485(220)	*485(220)	*595(270)		331(150)	375(170)	*529(240)		265(120)	331(150)	441(200)	
3'3" (500)	*507(230)	*573(260)	*772(350)	*1080(490)	287(130)	375(170)	617(280)	838(380)	243(110)	309(140)	507(230)	662(300)
1'8" (500)	*529(240)	*662(300)	*1036(470)	*1301(590)	287(130)	375(170)	573(260)	706(320)	221(100)	287(130)	463(210)	573(260)
Ground (0)	*529(240)	*706(320)	*1058(480)	*1389(630)	309(140)	375(170)	573(260)	750(340)	243(110)	287(130)	463(210)	595(270)
-1'8" (-500)	*573(260)	*617(280)	*948(430)		375(170)	353(160)	595(270)		287(130)	287(130)	463(210)	
-3'3" (-1000)	*507(230)				*507(230)				*463(210)			

Note : The maximum loads marked with an asterisk (*) were limited by the Excavator's hydraulic lifting capacity rather than by its static tilt load (tipping load) capacity.